

HealthWay®

MAX500

Smart Air Purifier

User Manual





Congratulations on your investment in your new HealthWay Professional Air Cleaning Device. Powered and designed around patented technology, your air cleaner is individually tested and certified to guarantee better than HEPA performance at ultrafine particle levels. Your choice of a HealthWay Air Cleaner will bring cleaner air and create a healthier indoor environment for years to come. Now let's get started.

Please visit **healthway.com** or Scan the QR code to register your HealthWay product and confirm your limited warranty. Your prompt product registration confirms your right to the protection available under the Terms and Conditions of your HealthWay limited warranty. Registering your purchase is the only way to guarantee that you will be notified by HealthWay of any issues that may arise concerning this product.



Table of Contents

What's in the Box	2
Important Safety Precautions	2
Specifications	3
Operation Buttons and Indicators	4
Operation Function Description	5
Filter Replacement & Maintenance	-8
Troubleshooting	10
Warranty Coverage	11

What's in the box

- HealthWay MAX500 Professional Air Cleaning System Main Unit | Qty 1
 - 5-stage prefilter (inside main unit) | Qty 2
 - Main filter (inside main unit) | Qty 1
 - ~~Power cord (pre-installed on unit)~~ | Qty 1
 - User Manual | Qty 1
-

Important Safety Precautions

Please read all instructions before operating your air cleaner. Basic precautions should always be observed when using electronic appliances to reduce the risk of fire, shock and injury.

1. Always unplug the air cleaner before moving it, opening any panels, changing any filter or cleaning the unit.
2. Do not place any foreign objects inside the unit, electric shock and injury could result.
3. Do not use the unit if any part is damaged or missing.
4. Do not run the power cord under carpeting, near heaters, registers, radiators, stoves or fireplaces.
5. Never operate the air cleaner in areas where combustible gases, vapors or any other flammable materials are present.
6. Never immerse or spray the unit with water or other liquids. Do not clean the unit under running water. Do not expose the unit to rain or excessive moisture.
7. The air cleaner is designed for indoor, residential use only.
8. Place the unit on a flat and level surface to allow for smooth operation.
9. Do not block the air quality sensor (reference exploded view for sensor location).

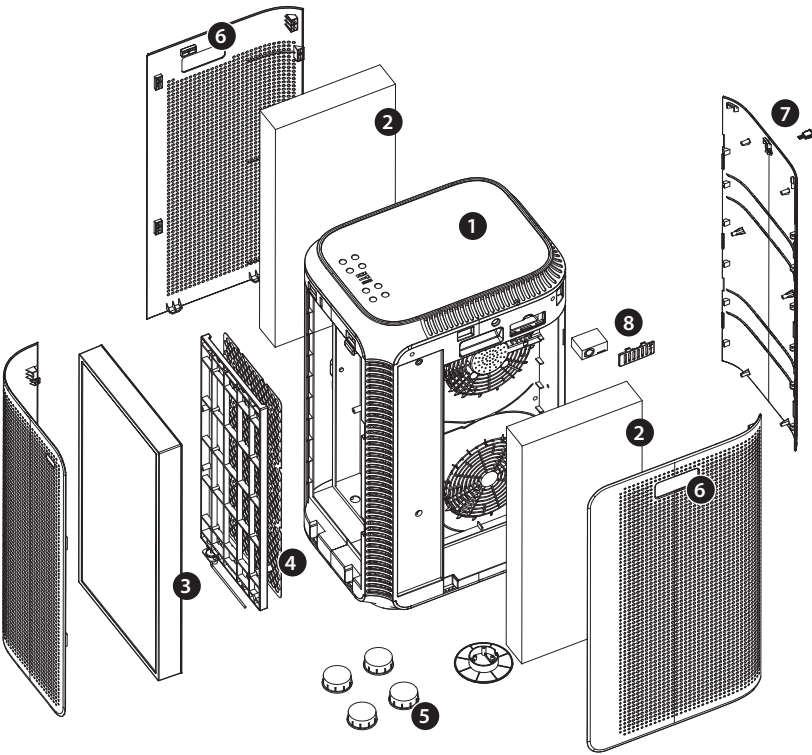

Specifications

1. TOP & CONTROL PANEL
2. PREFILTERS
3. MAIN FILTER
4. HIGH ENERGY GRID (DFS)
5. WHEELS
6. HANDLES
7. USB-C CHARGER
8. HIGH ACCURACY AIR QUALITY SENSOR

Model #	MAX 500
Power	100-240V, 50/60Hz
Wattage	80W
Unit Dimensions	16.3x12.5x27.0 in (413x318x686 mm)
Net Weight	26.5lbs / 12kgs
Shipping Dimensions	19.0x15.2x31.3 in (482x385x796 mm)
Shipping Weight	29.5lbs / 13.4kgs

Operation | Buttons and Indicators

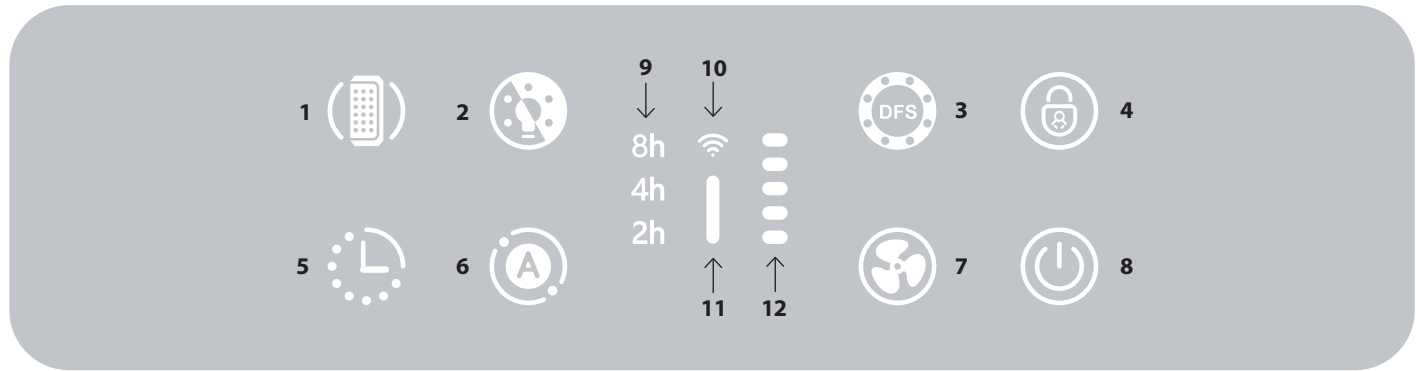

Control Panel - Buttons

1. Filter Life Button – Turns red when filters need replacement. Press and hold 3s to reset filter timer.
2. Display On/Off Button - To turn display on or off.
3. DFS Button – Turns red when DFS malfunctions. Press to turn DFS on/off.
4. Child Lock Button – Press and hold 3s to enable/disable child lock.
5. Timer Button – Press to set operation timer.
6. Auto Mode Button – Press to set auto mode.
7. Speed Control Button – Press to adjust fan speed.
8. Power Button – Turns unit on/off. When unit is locked, long press 3s to turn off unit.

Control Panel - Indicators







9. Timer Indicator – Corresponding timer lights up.
10. Wi-Fi Indicator – Shows Wi-Fi connectivity status.
11. AQI Indicator – Shows real time air quality (See below).
12. Speed Indicator – Shows current fan speed.

REAL-TIME AIR INDICATOR	INDICATOR
Excellent	Blue
Good	Green
Poor	Yellow
Heavy Pollution	Red

Operation | Function Description



Power ON / OFF

1. Remove all packaging and take the MAX500 unit out of the box. Lay the unit flat on its back. The power cord is located at the bottom of the unit. Unwind the power cord to your desired length.
2. Plug the unit into a 100-240V, 50-60Hz power outlet. The unit beeps once and all lights on the unit will flash a few times. After completion of self-check, the machine will stay on standby mode. The Power Button illuminates red, and all other lights will go out.
3. Press the Power Button  to start the unit in automatic mode. The automatic icon  and the power icon  both will illuminate in bright white, while all other buttons will illuminate in soft white. At the same time, the air quality indicator will show a corresponding color based on the indoor air quality PM2.5 reading.
4. Press the Power Button  again to turn off the unit.
5. When the unit first turns on and if the Wi-Fi is not connected, the Wi-Fi indicator  will flash for 30 seconds and turn off; if Wi-Fi is connected successfully, the  icon will stay lit.
6. In any mode, including when the child lock is enabled, press and hold the Power Button  for 3 seconds to turn off the unit.





Speed Control

1. When the unit is in operation, press the Speed Control Button  to cycle through the speeds: 1st, 2nd, 3rd, 4th, and 5th. The corresponding speed indicator illuminates as follows:
 - 1st speed: **1 bar**
 - 2nd speed: **2 bars**
 - 3rd speed: **3 bars**
 - 4th speed: **4 bars**
 - 5th speed: **5 bars**
2. When unit is set on the 5th speed, the ambient light will soften and dim in color.

Operation | Function Description





Automatic Mode

1. Press the Auto Mode Button  to enter automatic mode. The button  will illuminate in white. The unit will automatically adjust the speed according to the real-time air quality as follows:
 - Excellent air quality: **1st speed**
 - Good air quality: **2nd speed**
 - Poor air quality: **3rd speed**
 - Heavy pollution: **4th speed**
2. Pressing the Speed Control Button  to exit the automatic mode.
3. Please be advised that 5th speed is only available in Manual mode.









Timer

1. Press the button to enter timer. Select in sequence 2 hours (2h), 4 hours (4h), 8 hours (8h), and "cancel". When timer is activated, the corresponding Timer Indicator (2h/4h/8h) and the Timer Button  will both light up.
2. When the timer is activated, the Timer Indicator (2h/4h/8h) will remain lit for the entire duration of the timer. It will not decrease as time passes.
3. When the timer ends, the unit will turn off and enter standby mode, and the Power Button  will illuminate in red.





DFS Function

1. DFS is turned on by default. Press the DFS Button  to turn DFS on/off. When DFS turns on, the DFS Button  illuminates in white.
2. Press the DFS Button  again; the DFS Button  illuminates in red, indicating DFS is turned off.
3. If the DFS system shuts down automatically, the DFS Button  illuminates in red. If pressing the DFS Button  does not turn the DFS function back on, please contact Customer Service.









Display On/Off

1. Display is turned on by default. Press the Display On/Off Button  to turn off all lights on the unit. All other settings remain unchanged.
2. Pressing any button will wake the unit up for 10 seconds. If there is no operation during the 10s, the unit will re-enter display-off mode. If you press any other buttons within the 10s wake-up time, the unit will completely exit display-off mode, and the unit enters corresponding mode.
3. Press and hold the Display On/Off Button  for 5 seconds to disable or enable Wi-Fi function. Wi-Fi is enabled by default.







Filter Life

1. When the filter reaches the pre-set time, the Filter Life Button  will light in red as a reminder for filter replacement.
2. After replacing the filter, press and hold the Filter Life Button  for 3 seconds. All the lights on the unit flash 3 times. The Filter Life Button  will resume white and the filter timer restarts.
3. Re-Setting the filter timer: You can reset the filter timer at any time, even if the unit hasn't reached the filter timer limit. Press and hold the Filter Life Button  for 3 seconds to enter re-set mode. The button  will turn red and flash for 10 seconds. Press and hold the button  again for 3 seconds during the flashing period. Once reset, the Filter Life Button  will return to white, and the filter timer will restart.
4. If you do not press and hold the reset button within the 10 seconds, the unit will exit reset mode, and the original timer will continue.





Child Lock Function

1. Lock: To enable child lock, press and hold the Child Lock Button  for 3 seconds until the  button turns red. All buttons on the panel will be locked, and the machine will not respond to touch.
2. Unlock: To disable child lock, press and hold the Child Lock Button  for 3 seconds until the  button lights up in soft white. All buttons will return to normal function.
3. Disabling Child Lock: You can also disable the child lock and turn off the unit by Press and holding the Power Button  for 3 seconds or by unplugging the unit.

Operation | Wi-Fi Connection

1. To download the Smart Life app, search for **Smart Life** in the Apple App Store® or Google Play Store or scan the QR code.
2. During the setup process, ensure you are connected to a secure 2.4GHz Wi-Fi® network (DO NOT CONNECT TO 5GHz NETWORKS). Confirm that the network is working correctly.

NOTE: Make sure your phone has Bluetooth® turned on and is not currently connected to another Bluetooth device. Enter your correct Wi-Fi password.





3. Plug in and turn on your MAX500 air purifier. Press and hold the Speed Control Button  for 5 seconds, a soft beep indicates that Wi-Fi is ready to connect. The Wi-Fi indicator  flashes.
4. Open the Smart Life app, Log In or Sign Up

NOTE: You must create your own Smart Life account or use a third-party account (such as Google or Apple) to use third-party services and products.



5. The device will be automatically detected. Follow the in-app instructions to complete the connection. When connected successfully, the Wi-Fi indicator  will illuminate in white. Otherwise, it will keep flashing.

NOTE: Your phone must have **Turn on Location** enabled while your phone is connecting to your MAX500. This is required to establish the Bluetooth® connection. You can **Turn Location off** after the connection is completed.

Disable / Enable Wi-Fi

1. To completely disable the Wi-Fi function, press and hold the Display On/Off Button  for 5 seconds. A soft beep and the turning off of the Wi-Fi indicator  will confirm that the Wi-Fi function is disabled.
2. To turn Wi-Fi back on, press and hold the Display On/Off Button  for 5 seconds. A soft beep and the turning on of  the Wi-Fi indicator will confirm that the Wi-Fi function is enabled.

Remove a Connected Mobile Device

1. Power on and turn on your MAX500, press and hold the Speed Control Button  for 5 seconds, the Wi-Fi indicator  will start flashing. Previous connected devices have been removed successfully.
2. To add a new device, refer to the Wi-Fi connection instructions. Turn to manual connection if auto connection fails after being in Wi-Fi connectivity mode for 2 minutes.



Product Warnings

WARNING: To reduce the risk of electric shock, this equipment has a polarized plug (one blade is wider than the other). This plug will fit in a polarized outlet only one way. If the plug does not fit fully in the outlet, reverse the plug. If it still does not fit, contact qualified personnel to install the proper outlet. Do not alter the plug in any way.

WARNING: RISK OF ELECTRIC SHOCK – These servicing instructions are for use by qualified personnel only. To reduce the risk of electric shock, do not perform any service other than that contained in the operating instructions unless you are qualified to do so.

WARNING: The appliance is not to be used by children or persons with reduced physical, sensory or mental capabilities, or lack of experience and knowledge, unless supervised or they have been given instruction.

This product complies with the maximum allowable concentration of ozone of 0.050 parts per million by volume (ppmv) in a 24 h period.



Filter Replacement & Maintenance



- Filters need to be replaced or maintained properly to maximize the unit's performance
- The Following is the recommended maintenance schedule for most environments. Filters will need to be replaced/cleaned more often if the unit is being used in a heavily polluted environment
- The filters are designed to work optimally with HealthWay's proprietary DFS technology. For proper function and maximum performance, use only authentic HealthWay filters.

High Energy Grid – cleaned every 6 months

Prefilters – replace both Prefilters every 12 months

Main filter - replace every 12 months



- When the Filter Life Button (🔴) turns red, it indicates that the filters are due for replacement. Please order only authentic HealthWay filters via your local representative.

Prefilter Replacement and Maintenance

1. Turn unit off and unplug from outlet.
2. The prefilters are located on the left and right sides of the unit. Change/vacuum one at a time.
3. Open the side panel, (FIG 1) take out the prefilter by pulling the tab on top (FIG 2). Replace it with a new one.
4. Repeat these steps to replace/vacuum the other prefilter.
5. If there is a high level of particulates and/or animal hair in the environment, vacuum both sides of the prefilter between filter changes.

Note: To reinstall the left panel, first remove the front panel. Then, install the left panel before putting the front panel back in place.

Main Filter Replacement and Maintenance

1. Turn unit off and unplug from outlet.
2. The main filter is located at the front. After removal of the front panel, locate the filter lock on the left front side (FIG 3). When the filter lock is horizontal, the main filter is locked. Turn the lock to a vertical position to unlock the main filter (FIG 4).
3. Carefully pull out the main filter using the two handles and replace it with a new one (FIG 6). Lock the new main filter by turning the lock back to horizontal position.
4. Reinstall the front panel.

Resetting the Filter Timer

- Press and hold the Filter Life Button (🔌) for 3 seconds. All the lights on the unit flash 3 times. The Filter Life Button (🔌) will resume white and the filter timer restarts.

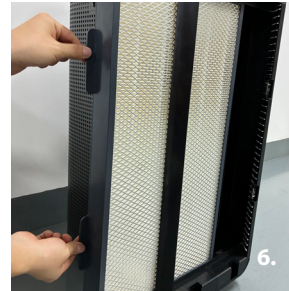
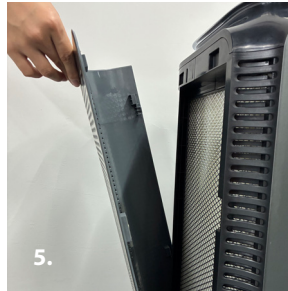
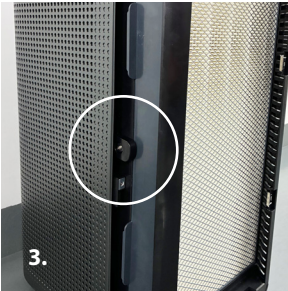

Troubleshooting

Unit will not turn on.

- Check the power connection on both ends: whether the unit is plugged into a working outlet, whether the receptacle is correctly inserted into the unit.
- Check if the unit's covers are in place and snapped shut. There are three covers – front, left and right.

The unit turns on but no air blows out.

- Check if the plastic wrap on main filter or prefilter has been removed.
- Increase the fan speed and see if the problem is addressed.
- Move unit to a different outlet/make sure unit is plugged directly into a standard outlet.

Unit is ON, but no change in speed.

- Move unit to a different outlet/make sure unit is plugged directly into a standard outlet
- Further examination by a trained technician is required. Call HealthWay Customer Service or local distributor.

The Filter Life Button turns red.

- The filters need replacement. See the Maintenance section of this manual for filter replacement instructions.

The DFS Button turns red.

- Clean DFS Grid and toggle DFS back on. If Red light returns, contact local distributor or HealthWay Customer Service.

Warranty Coverage

HealthWay offers a 5 Year Limited Warranty. 5 Years on motor and blower. 1 Year on electronic components.

Customers in the United States should complete their Product Warranty Registration within 10 days of purchase.

Customers outside of the United States should contact the local distributor to complete the product registration process.

To make a product claim, contact your local distributor.

Limited Warranty

This limited warranty applies only to the repair or replacement of any manufactured or supplied part of this product which, upon inspection by HealthWay authorized personnel, proves to have failed in normal use due to defects in material or workmanship. The sole responsibility of HealthWay under this Limited Warranty is, in its sole discretion, to either repair or replace a duly registered product (or defective part thereof) with the same or a comparable model within a reasonable period, subject to the following exclusions, limitations, statutory rights, and warranty claim procedures. This Limited Warranty is exclusive, and HealthWay expressly disclaims all other or additional warranties, whether written or oral, expressed or implied, including, but not limited to, warranties of merchantability, workmanship, or fitness for a particular purpose.

Exclusions

A. This Limited Warranty does not apply, or is void, as to any product or part damaged by (1) accident, misuse, abuse, or lack of reasonable care or normal maintenance; (2) installation or operation under conditions other than those recommended by HealthWay; (3) subjecting the product to any but the specified voltage; (4) servicing or disassembly by unauthorized personnel; (5) removing or defacing the serial number; or (6) modifying the original factory-assembled unit in any way.

B. THIS LIMITED WARRANTY DOES NOT APPLY TO SHIPPING CHARGES FOR PRODUCT SHIPPED TO OR FROM THE FACTORY OR DESIGNATED SERVICE

CENTER IN CONNECTION WITH WARRANTY CLAIMS NOR DOES IT APPLY TO ANY DAMAGES OCCURRING DURING EACH SHIPMENT.

C. This Limited Warranty does not apply to installation, removal, reinstallation, and/or related expenses. This Limited Warranty does not apply to replaceable filters and high-energy grid wires.

Limitations

HealthWay shall not be liable for property, incidental, and/or consequential damages of any kind and, unless otherwise described by applicable state law, HealthWay shall not be liable for personal injury resulting from malfunctions, defects, misuse, improper operation or installation, or alteration of an HealthWay product or any part thereof. The exclusive remedy for a breach of this Limited Warranty is the repair or replacement of the defective product.

In no case shall liability under any other remedy described by law exceed the purchase price of the product.

Statutory Rights

This Limited Warranty, subject to the above exclusions and limitations, gives you specific legal rights in addition to statutory rights you may have under applicable state law. Some states, however, do not permit the limitation or exclusion of incidental or consequential damages, so much limitation may not apply to you. To the extent that any provision of this Limited Warranty is inconsistent with applicable law, such provision shall be deemed void or amended, as necessary, to comply with such law.

HealthWay Customer Service

US Corporate Office

4776 Salina St., Pulaski NY USA 13142

Tel: (+1) 315-298-2904 Toll Free 1.800.843.3860

Email: hwservice@healthway.com

Please contact your local dealer for timely and professional service.

healthway.com

