

HealthWay Inline

FRONT & SIDE LOAD
DFS SOLUTIONS



HealthWay manufactures a best in class modular and scalable air filtration solution for commercial applications. We use a proprietary, electronically enhanced filtration technology for high efficiency while maintaining a low pressure drop.

HealthWay Inline

Front & Side Load DFS Solutions

 Disinfecting Filtration System (DFS) is our proprietary electronically enhanced filtration technology.

Features

Total System Efficiency: Captures 98% of particles at 0.3 microns (MERV 16)

Low Pressure Drop: 0.27" wc at 500 FPM

Extended Filter Life: V-bank design enables up to 200 grams of holding capacity yielding up to 36 months of filter life. Suggested change out at 0.54" wc.

Scalable: Modular design allows for flexible array configuration to fit HVAC dimensions and CFM requirements.

Ease of Installation Maintenance: Filter access is available in front or side load orientation.

Bypass Elimination: Proprietary gasketing and interlocking fasteners are engineered to prevent filter bypass.

Energy Consumption: Operating power is less than 9 watts.

HEALTHWAY DFS PERFORMANCE	
Efficiency	98% (MERV-16) at 0.3 micron
Pressure Drop	0.27 in WC at 500 FPM
Filter Life	~12-36 months (dependent on environment)
Captures	Smoke • Pollen Mold • Bacteria • Viruses

DFS INLINE POWER REQUIREMENTS					
Model	Power Requirement			FLA	Rated Power Usage (per module)
	V	Hz	Phase	AMPS	WATTS
2000IL	120	60	1	0.12	18
1000IL	120	60	1	0.12	18

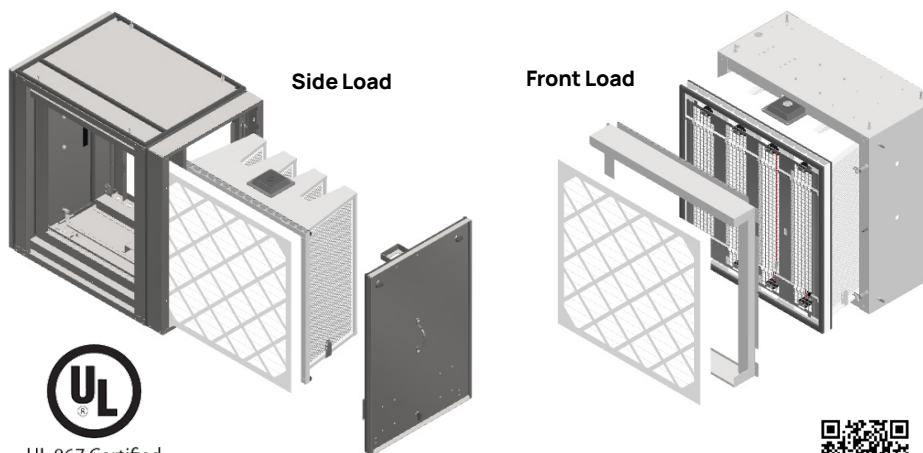

UL 867 Certified

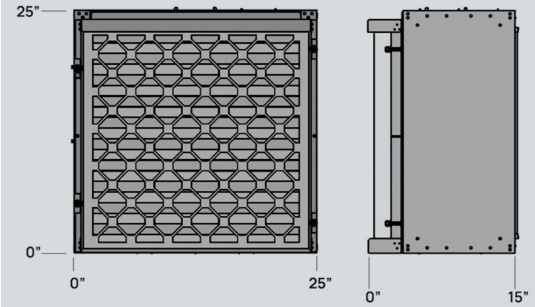

2000IL FRONT LOAD

Height – 25" (635 mm)

Width – 25" (635 mm)

Depth – 15" (381 mm)

Weight – 50 lbs (22.68 kg)

1000IL FRONT LOAD

Height – 13" (330.7 mm)

Width – 25" (635 mm)

Depth – 15" (381 mm)

Weight – 36 lbs (16.3 kg)

2000IL SIDE LOAD

Height – 23.5" (596.9 mm)

Width – 27.7" (703.58 mm)

Depth – 18" (457.2 mm)

Weight – 95 lbs (43.09 kg)

1000IL SIDE LOAD

Height – 23.5" (596.9 mm)

Width – 15.79" (401.06 mm)

Depth – 18" (457.2 mm)

Weight – 70 lbs (31.75 kg)

2000IL + 1000IL	
ITEM	PART #
2000IL* Front Loaded	6000-K-01001-N-0000
1000IL* Front Loaded	6000-K-01000-N-0000
2000IL* Front Loaded	7000-K-01100-N-0000
1000IL* Front Loaded	6000-K-01200-N-0000

FILTERS	
ITEM	PART #
2000IL* Main Filter	3400-A-70000-N-0000
1000IL* Main Filter	1700-A-70000-N-0000
2000IL* Pre-Filter	FT-10-24x24x2
1000IL* Pre-Filter	FT-10-12x24x2